

CAREFULLY READ THE INSTRUCTIONS BEFORE INSTALLING

- A) LEVER ROSE SUB-ASSEMBLY
- B) BACKPLATE SCREW
- C) INSIDE BACKPLATE
- D) SPINDLE
- E) SPINDLE CLIP
- F) OUTSIDE BACKPLATE
- G) LATCH
- H) FACEPLATE
- I) LATCH SCREWS
- J) STRIKE PLATE
- K) DUST BOX
- L) HEX WRENCH
- M) SET SCREW
- N) PRIVACY PIN

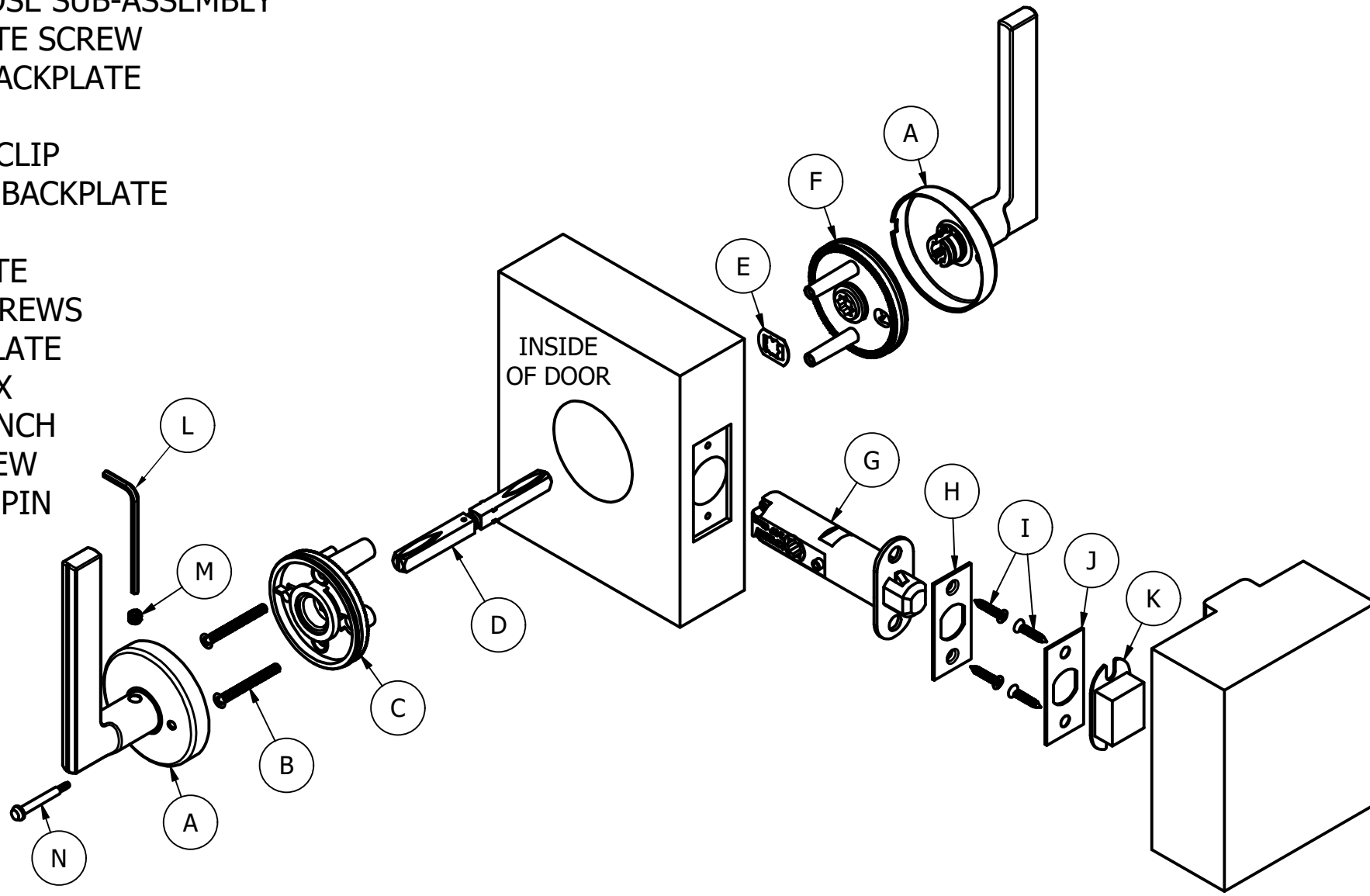

STEP 1)

- A. PREPARE DOOR ACCORDING TO **DP-473**.
- B. INSERT THE LATCH (G) INTO THE EDGE BORE. INSERT THE FACEPLATE (H) INTO THE RECESS OVER THE LATCH BOLT AND FASTEN TO THE DOOR WITH THE PROVIDED SCREWS (I).

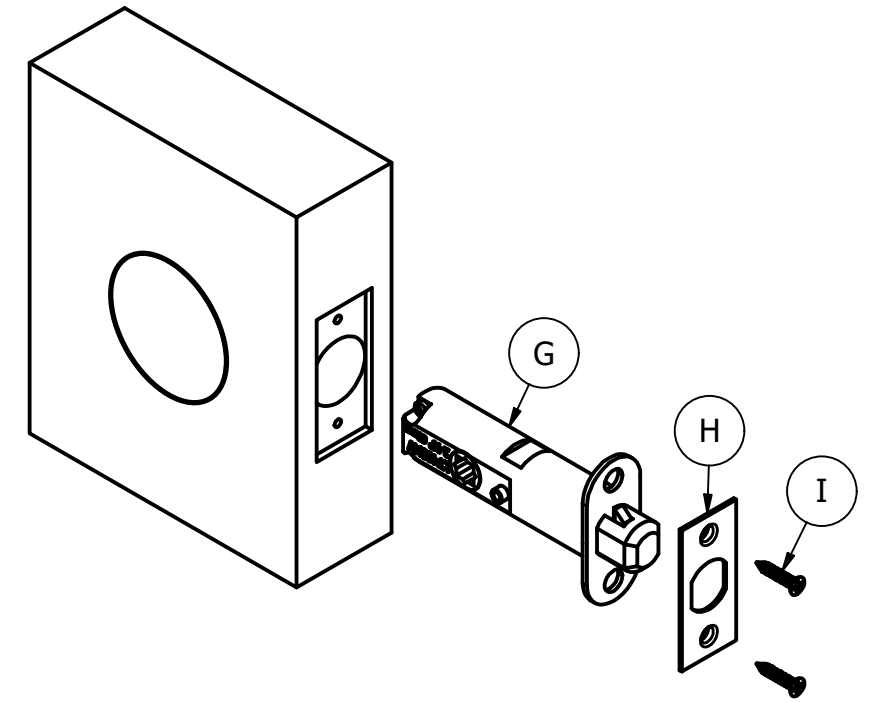

STEP 2)

- A. INSERT THE END OF THE SPINDLE (D), THAT DOES NOT HAVE NOTCHES (2), INTO THE LATCH FROM THE INSIDE OF THE DOOR, WITH THE GROOVED CUTOUT (1) FACING THE DIRECTION OF THE SET SCREW HOLE OF THE LEVER, UNTIL IT STOPS.
- B. SECURE THE SPINDLE BY SLIDING THE RETAINING CLIP (E) ONTO THE OUTSIDE END OF THE SPINDLE UNTIL FIRMLY SEATED AGAINST THE LATCH.

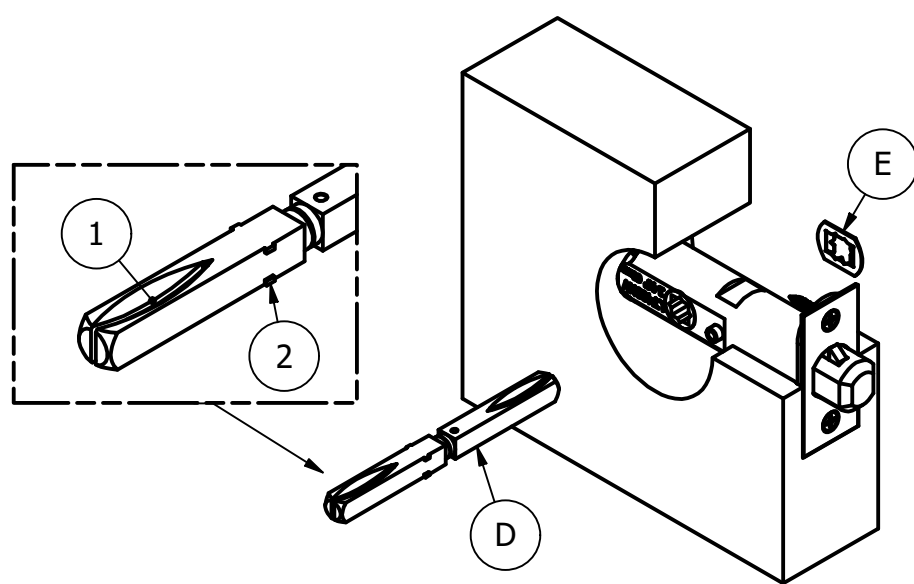

STEP 3)

- A. FROM THE INSIDE OF THE DOOR, INSERT THE INSIDE BACKPLATE (C) ONTO THE SPINDLE WITH THE PRIVACY PIN HOLE (1) CLOSEST TO THE DOOR EDGE.
- B. FROM THE OUTSIDE OF THE DOOR, INSERT THE OUTSIDE BACKPLATE (F) OVER THE SPINDLE, PRIVACY PIN HOLE CLOSEST TO THE DOOR EDGE.
- C. FASTEN THE BACKPLATES TOGETHER WITH THE 2X BACKPLATE SCREWS (B).

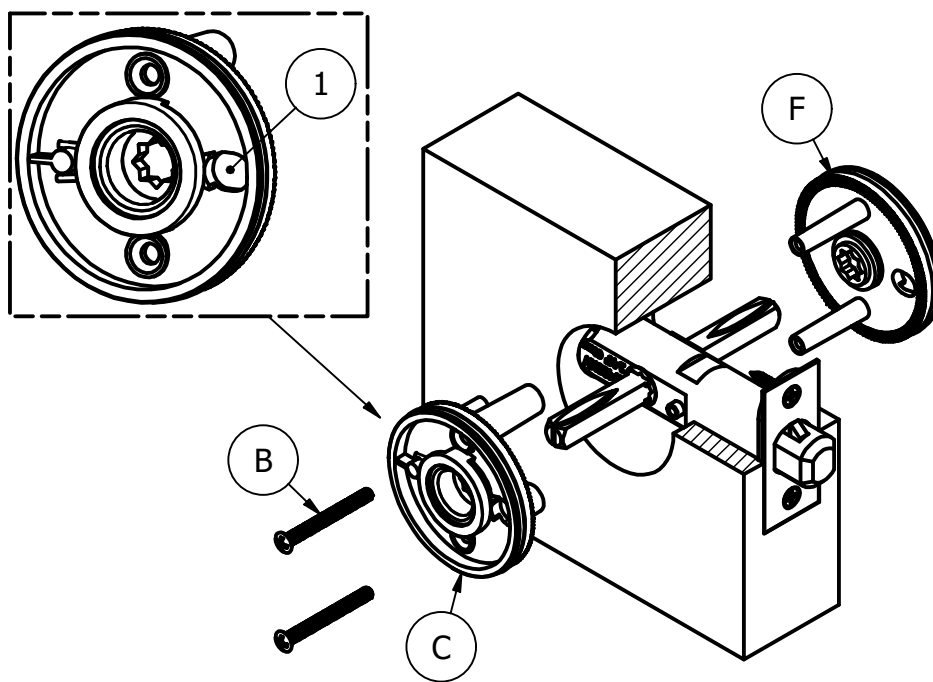

STEP 4)

- A. WITH THE LEVER IN THE ORIENTATION DETERMINED BY THE GENERAL CONTRACTOR AND THE PRIVACY HOLE (1) CLOSEST TO THE DOOR EDGE, INSERT THE INSIDE LEVER-ROSE SUB-ASSEMBLY ONTO THE SPINDLE. FIRMLY PRESS THE TRIM FLUSH AGAINST THE DOOR SURFACE.
- B. INSERT THE LEVER SET SCREW (M) AND TIGHTEN FIRMLY WITH THE HEX WRENCH (L).
- C. REPEAT THESE STEPS FOR THE OUTSIDE LEVER.

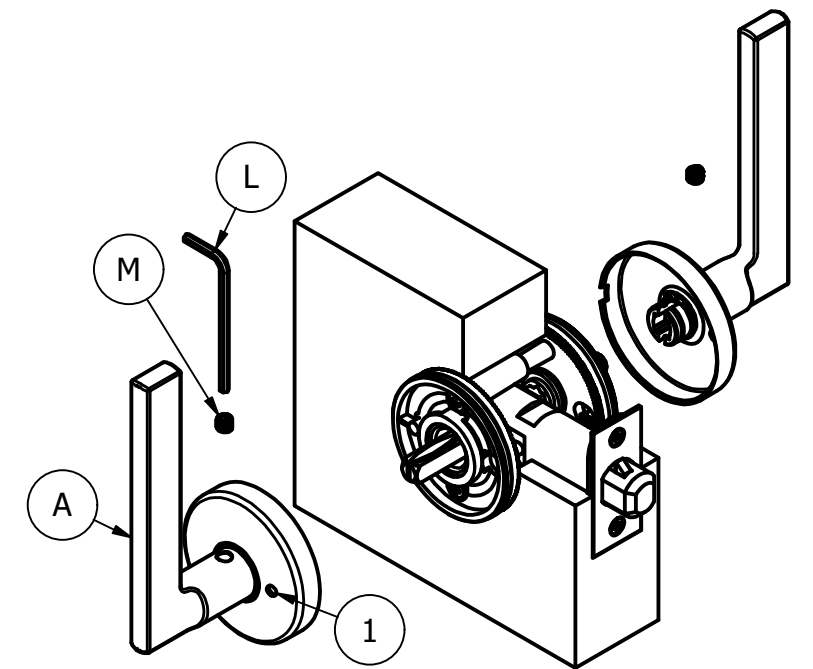

STEP 5)

- A. INSERT THE PRIVACY PIN (N) INTO THE PRIVACY PIN HOLE (1) OF THE INSIDE ROSE AND TIGHTLY THREAD INTO THE LATCH.

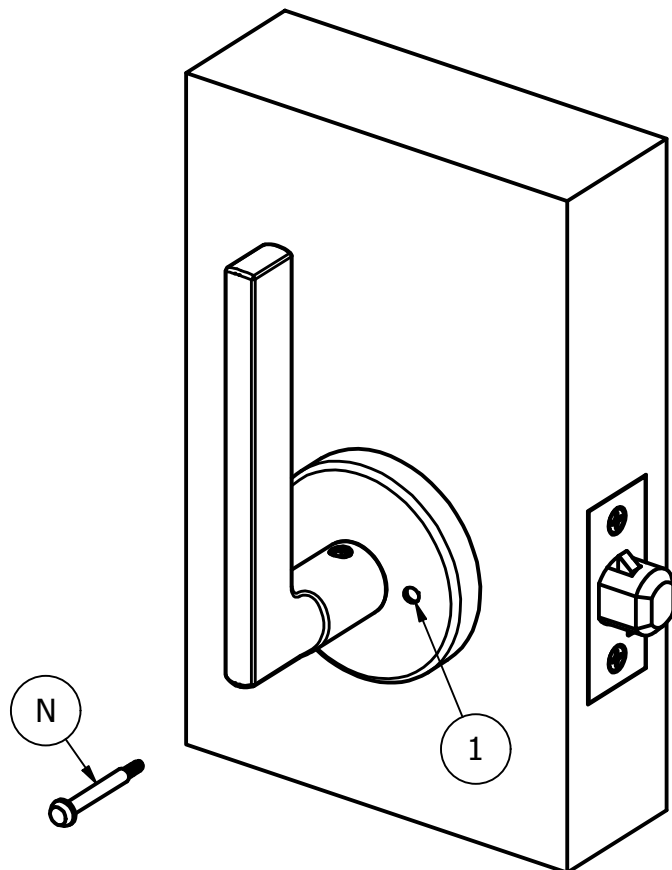

STEP 6)

- A. PREPARE THE DOOR FRAME STRIKE AREA ACCORDING TO **DP-461**.
- B. INSERT THE DUST BOX (K) INTO THE PREPARED CAVITY.
- C. INSERT THE STRIKE PLATE (J) OVER THE DUST BOX AND THEN INSERT 2X STRIKE FASTENERS (I) TO SECURE THE STRIKEPLATE. ENSURE THAT THE STRIKEPLATE IS SEATED FLUSH WITH THE FRAME SURFACE.

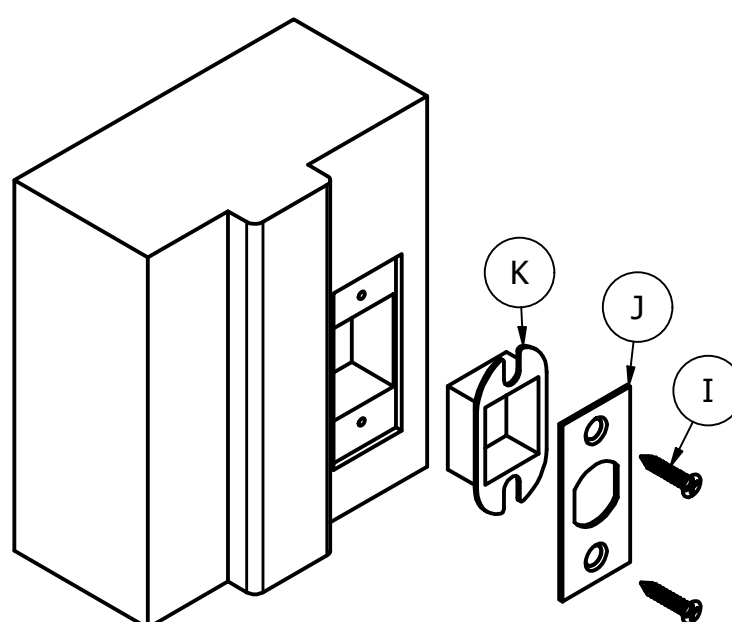

STEP 7)

- A. VERIFY THAT THE LATCH BOLT PROPERLY ENGAGES THE STRIKE PLATE BY CLOSING THE DOOR. IF IT DOES NOT LATCH, REPOSITION THE STRIKE PLATE TO ALLOW THE LATCH TO FUNCTION PROPERLY.

