

Description:
SL6 INSTALLATION INSTRUCTIONS
 (TRIM SHOWN: SL6-1 PRIVACY, TK x COIN TURN)

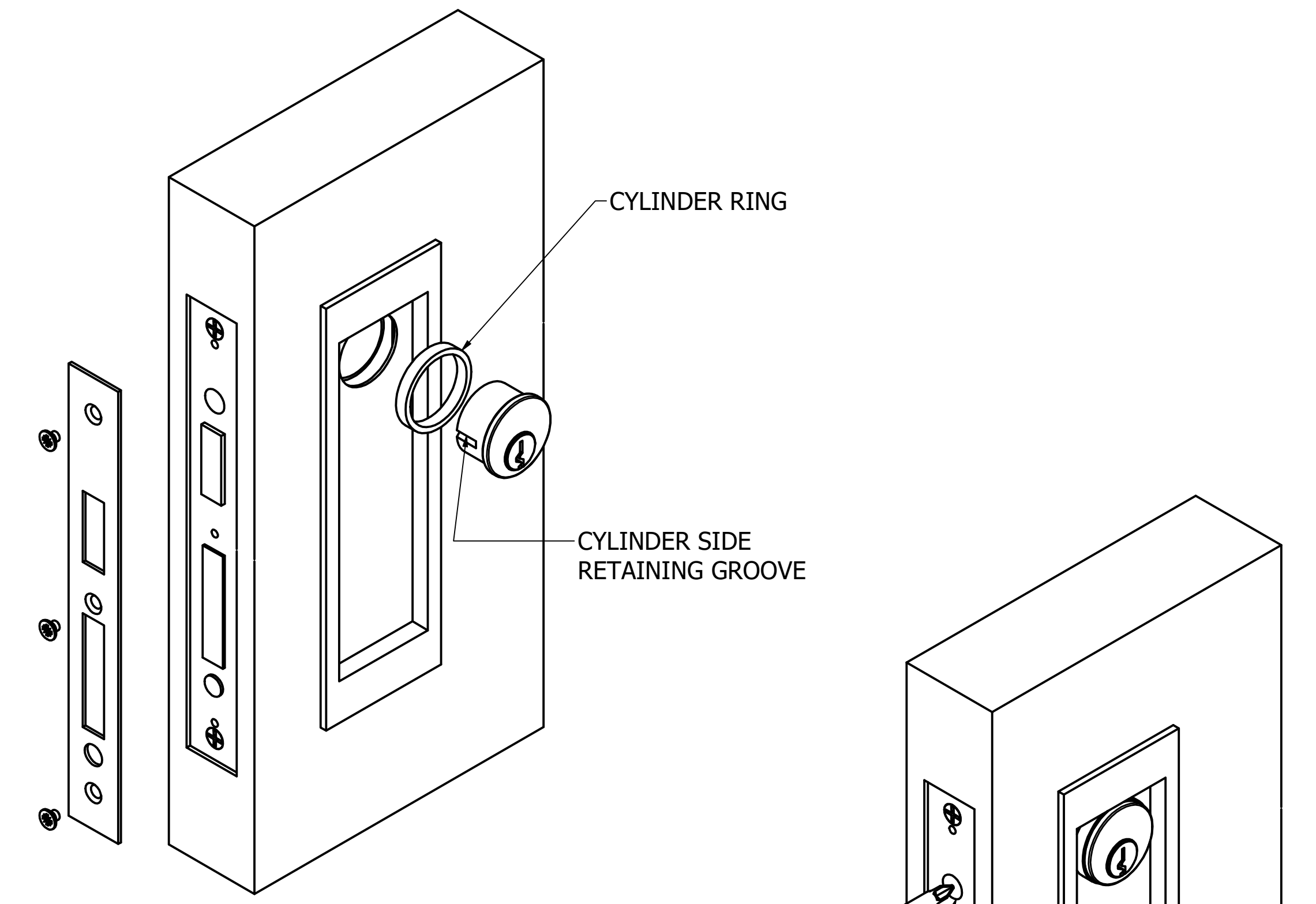

Drawing No: IT-393	
Drawn By: JWB	Orig.Date 09-23-22
Rev. Date: 03-06-25 JDK	Rev.: C

- STEP 3)
- FOR CYLINDER FUNCTION, SL6-5, MAKE SURE THE FACEPLATE (5) IS REMOVED TO ALLOW ACCESS TO THE CYLINDER RETAINING SCREW INSIDE THE LOCKCASE.
 - REPEAT STEPS 1 & 2 EXCEPT WITH APPROPRIATE TRIM SUB-ASSEMBLY SL6-5.
 - AFTER TRIM IS INSTALLED, INSERT THE CYLINDER AND CYLINDER RING BY THREADING INTO THE LOCK CASE UNTIL CYLINDER WILL NO LONGER ROTATE. ROTATE COUNTER CLOCKWISE UNTIL THE KEY IS IN THE VERTICAL POSITION (NOT TO EXCEED MORE THAN 1 FULL TURN).
 - INSERT A SCREW DRIVER INTO THE CYLINDER RETAINING SCREW ACCESS HOLE AND TIGHTEN THE SCREW INTO THE CYLINDER. MAKE SURE THE CYLINDER IS ALIGNED PROPERLY AND THE SCREW FINDS THE SIDE RETAINING GROOVE.
 - CHECK FOR SMOOTH OPERATION. IF LOCK IS OPERATING RESISTFULLY, SLIGHTLY LOOSEN TRIM SCREWS AND OPERATE LOCKSET FROM BOTH SIDES WITH TURN KNOB AND CYLINDER. RE-TIGHTEN THE TRIM SCREWS ONCE LOCKSET IS OPERATING SMOOTHLY.
 - REPLACE THE FACEPLATE.



- STEP 1)
- PREPARE DOOR ACCORDING TO DP-393.
 - INSERT THE LOCK CASE (4) INTO THE EDGE PREP.
 - INSERT THE 2X FASTENERS (7) TO SECURE THE LOCK CASE.
 - ASSEMBLE THE FACEPLATE (5) WITH THE 3X FASTENERS (6).

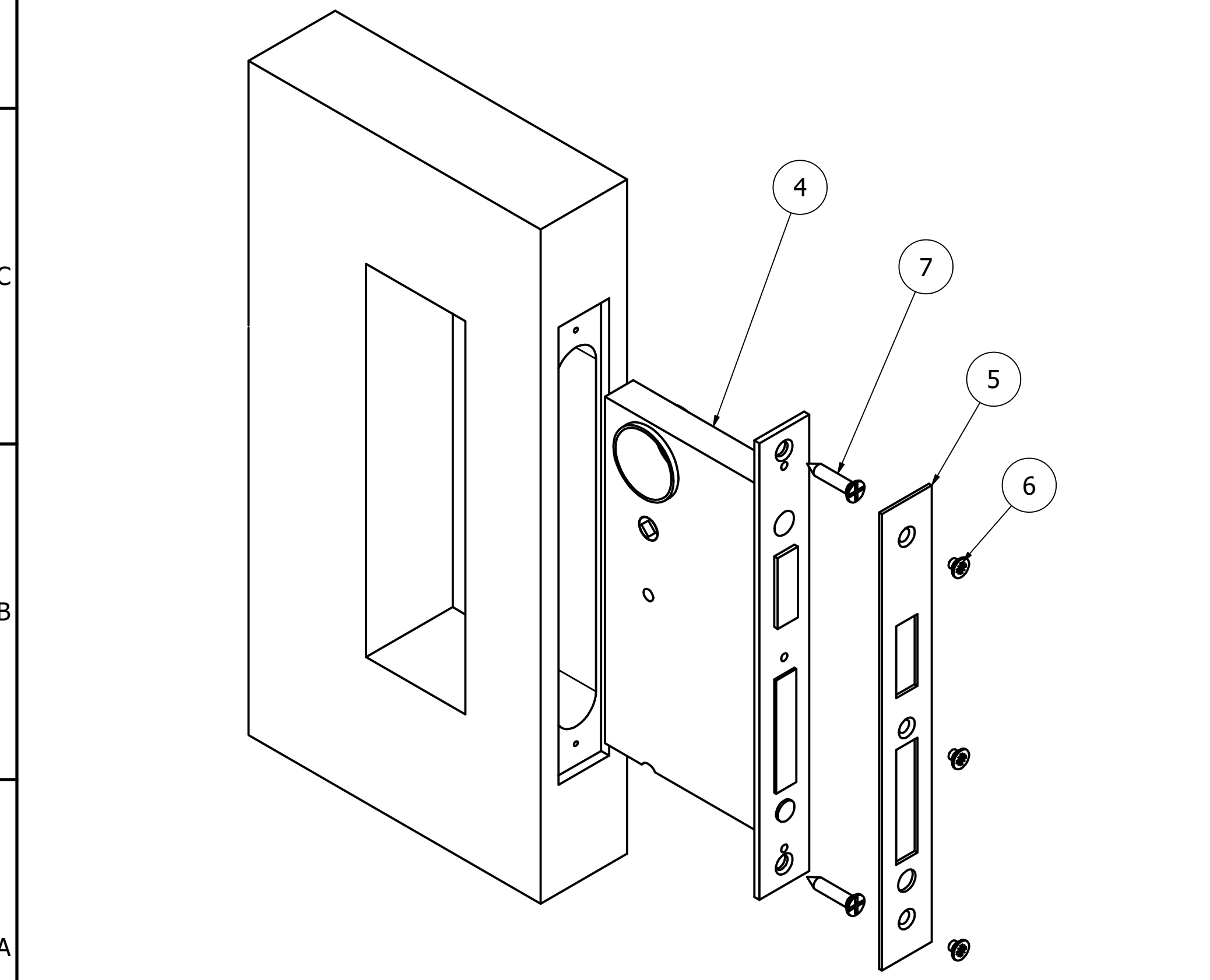

- STEP 2)
- LOCATE OUTSIDE "COIN TURN" TRIM SUB-ASSEMBLY (3). ORIENT THE COIN TURN CROSS SLOT IN THE VERTICAL DIRECTION (CASE IS IN UN-LOCKED POSITION). INSERT INTO THE TURN KNOB HUB ON THE LOCKCASE.
 - WITH THE THUMB TURN IN THE VERTICAL POSITION, INSTALL TRIM SUB-ASSEMBLY INTO THE TURN KNOB HUB.
 - INSERT THE 2X TRIM FASTENERS (5) TO A LOOSE-TO-SNUG FIT. CHECK FOR SMOOTH OPERATION OF LOCKSET.
 - IF TRIM IS OPERATING SMOOTHLY, GRASP/PINCH BOTH SIDES OF TRIM TIGHT AGAINST THE DOOR SURFACE, THEN TIGHTEN SCREWS. RECHECK FOR SMOOTH OPERATION.
 - IF LOCKSET OPERATION IS TIGHT, LOOSEN TRIM SCREWS AND REPEAT STEP D.

