

# PASSAGE TRIM INSTALLATION INSTRUCTIONS

## LARGE ROSE APPLICATION

Passage sets require a 2 1/8" bore and a 1" edge bore.

- A) Passage latch kit components
- B) Lever and rose trim set
- C) Blackplate outside
- D) Blackplate inside
- E) Split spindle
- F) Retainer clip
- G) Serrated lock washer
- H) Backplate screws
- I) Set screws

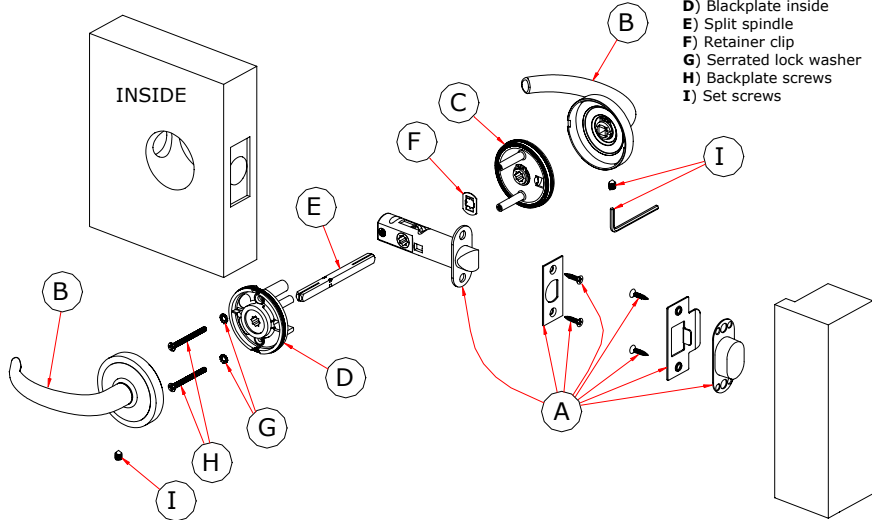
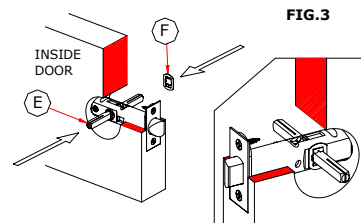
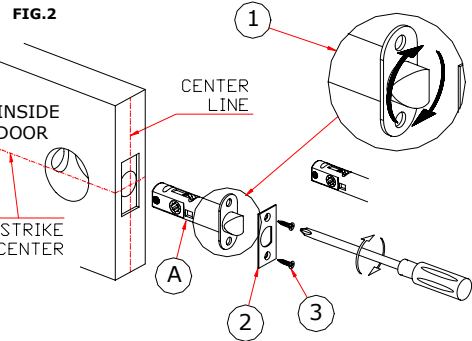
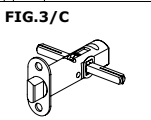
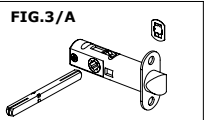

FIG. 1

BEFORE ASSEMBLING THE SET, CAREFULLY READ THE INSTALLATION INSTRUCTIONS.



**STEP 4)** INSERT THE PASSAGE SPINDLE (E) INTO THE LATCH FROM INSIDE OF DOOR. GROOVED CUTOUT ON SPINDLE MUST FACE DOWN. FROM EXTERIOR SIDE OF DOOR, PRESS RETAINER CLIP (F) ONTO SPINDLE, MAKING SURE THAT THE CLIP AND SPINDLE NOTCHES ARE SNUG AGAINST THE LATCH HUB.



**TOP VIEW**  
IN ORDER TO MAINTAIN THIS POSITION OF THE SPINDLE, SIDE THE RETAINING CLIP ONTO THE OPPOSITE END OF THE SPINDLE UNTIL IT MAKES CONTACT WITH THE OTHER SIDE OF THE LATCH. THE RESULT SHOULD CORRESPOND TO FIGURE 3/A FIGURE 3/B FIGURE 3/C

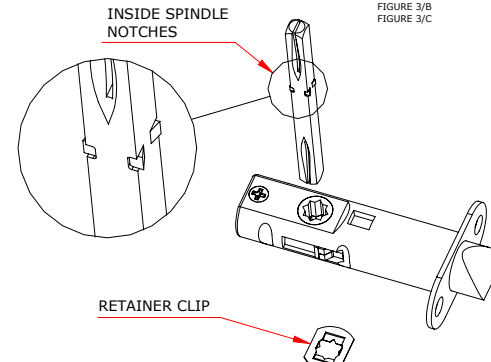
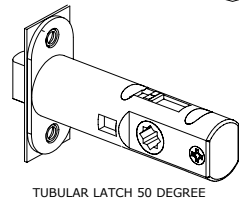
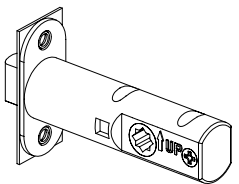

FIG. 3/B



TUBULAR LATCH 50 DEGREE



TUBULAR LATCH 28 DEGREE

**STEP 1)** THE DOOR SHOULD BE PREPARED USING THE TUBULAR LATCH DOOR PREPARATION TEMPLATE SUPPLIED WITH THE LEVERSET. IF TEMPLATE ALIGNMENT AND DRILLING HAVE BEEN CARRIED OUT PROPERLY, THE RESULT SHOULD CORRESPOND TO FIGURE 2.

INSERT THE LATCH (A) INTO THE EDGE BORE AND TURN THE BOLT IN THE CORRECT POSITION (PICTURE 1). SECURE THE FACEPLATE (2) WITH ITS SCREWS (3)

**NOTE:** FOR INSTALLATION USING A 28 DEGREE ROTATION LATCH, TAKE NOTE OF THE "UP" DESIGNATION ON THE SIDE OF THE LATCH TUBE AND INSERT LATCH WITH PROPER ORIENTATION.

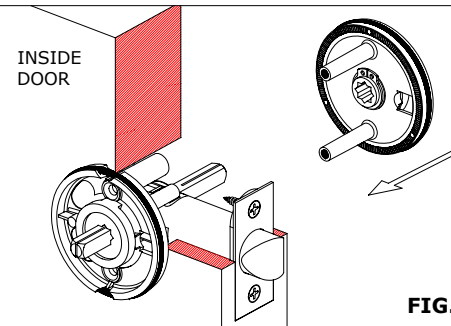

FIG. 4

**STEP 3)** PLACE BOTH BACKPLATES ONTO SPINDLE AND SLIDE THEM FLUSH AGAINST THE DOOR.

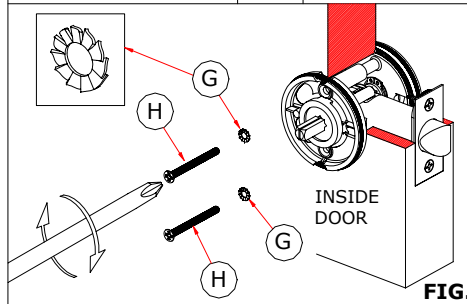

FIG. 5

**STEP 4)** FASTEN THE BACKPLATES USING SCREWS (H) AND RETAINER WASHER (G).

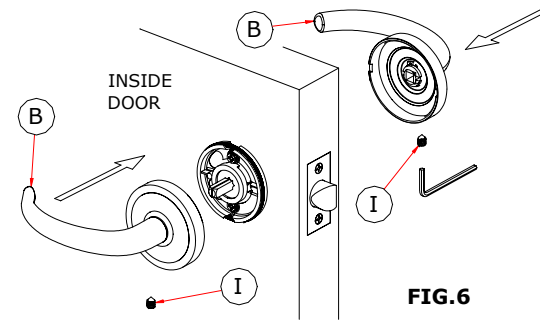

FIG. 6

**STEP 5)** PLACE THE LEVER AND ROSE TRIM SET (B) ONTO THE BACKPLATE AND SLIDE IT FLUSH AGAINST THE DOOR, FASTEN WITH SET SCREWS (I) USING THE ALLEN KEY.

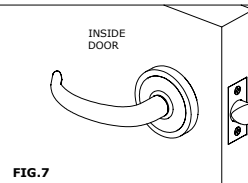

FIG. 7

**STEP 6)** THE SET PROPERLY INSTALLED SHOULD CORRESPOND TO FIGURE 7.

**NOTE:** HORIZONTAL POSITION OF LEVER CAN BE ADJUSTED SLIGHTLY REMOVING TRIM SET, LOOSENING THE BACKPLATE SCREWS, AND RETIGHTENING SCREWS AND REPLACING TRIM.

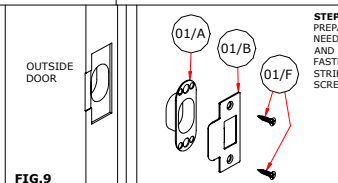

FIG. 9

**STEP 8)** PREPARED THE DOOR FRAME AS NEEDED TO ACCEPT THE DUST BOX AND STRIKEPLATE. FASTEN DUST BOX (01/A) AND STRIKEPLATE (01/B) WITH STRIKE SCREWS (01/F).

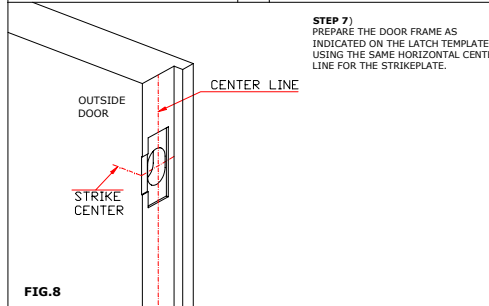
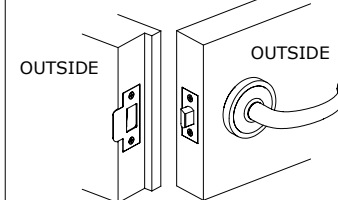

FIG. 8

**STEP 7)** PREPARE THE DOOR FRAME AS INDICATED ON THE LATCH TEMPLATE USING THE SAME HORIZONTAL CENTER LINE FOR THE STRIKEPLATE.

FIG. 10



**STEP 9)** TO COMPLETE INSTALLATION OF TRIM SET DO A FINAL CHECK TO VERIFY PROPER OPERATION. NOTE THAT THE LATCH BOLT MUST CORRECTLY FIT INTO THE STRIKEPLATE TO FUNCTION PROPERLY. RECHECK DOOR PREPARATION AND INSTALLATION STEPS IN CASE THE SET DOESN'T WORK PROPERLY.

frascio

COD.4102059