

NOTES:
 1) FOR USE WITH THE SLT600 LATCH.
 2) DIMENSION "X" IS VARIABLE DEPENDING ON DOOR THICKNESS. MAKE SURE THE CENTER-LINE OF STRIKE IS SAME AS CENTER-LINE OF LOCK CASE.
 3) STRIKE LOCATION ON FRAME MUST BE ADJUSTED FOR THICKNESS OF DOOR WHEN SILENCERS ARE USED.
 4) FOR OPPOSITE HANDING, MIRROR DIMENSIONS TO OTHER SIDE OF JAMB.

Description:
SLT600 STRIKE PREP



TOLERANCES UNLESS OTHERWISE SPECIFIED:
 X.X (METRIC)= ±0.5
 X.XX(METRIC)= ±0.15
 0.00"(UNIFIED)= ±.015"
 0.000"(UNIFIED)= ±.005"

Drawing No:
DP-461

Drawn By: **JDK**

Orig.Date: **09-04-24**

Rev. Date:

Rev.:

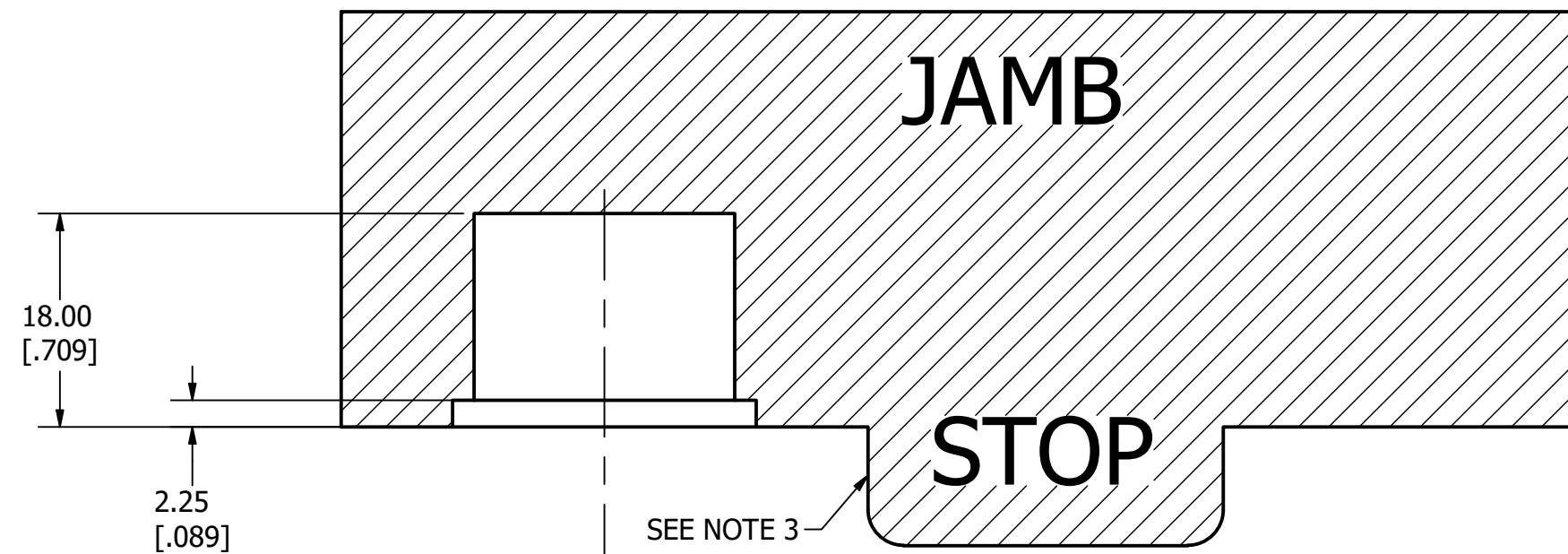

SECTION A-A

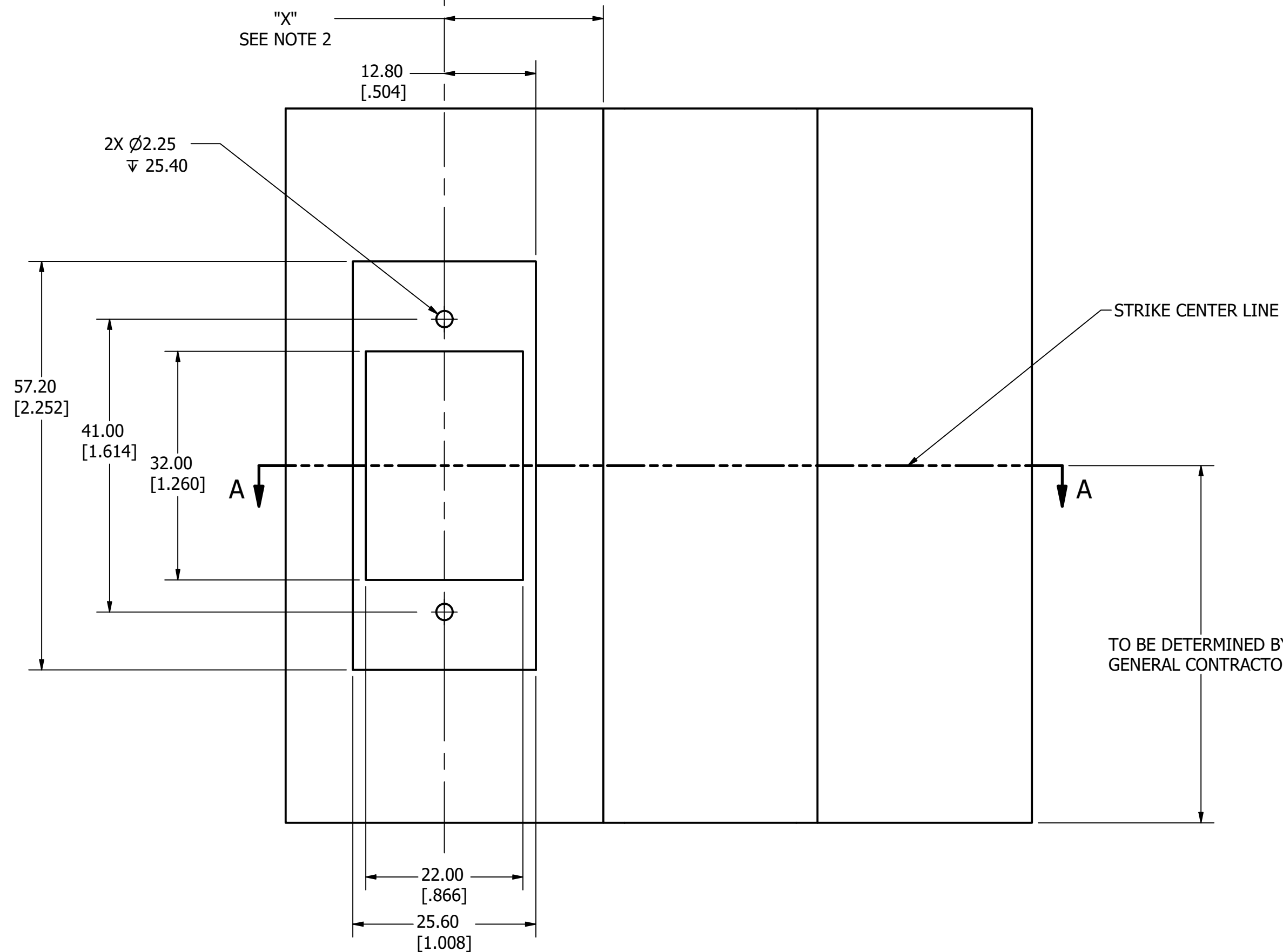
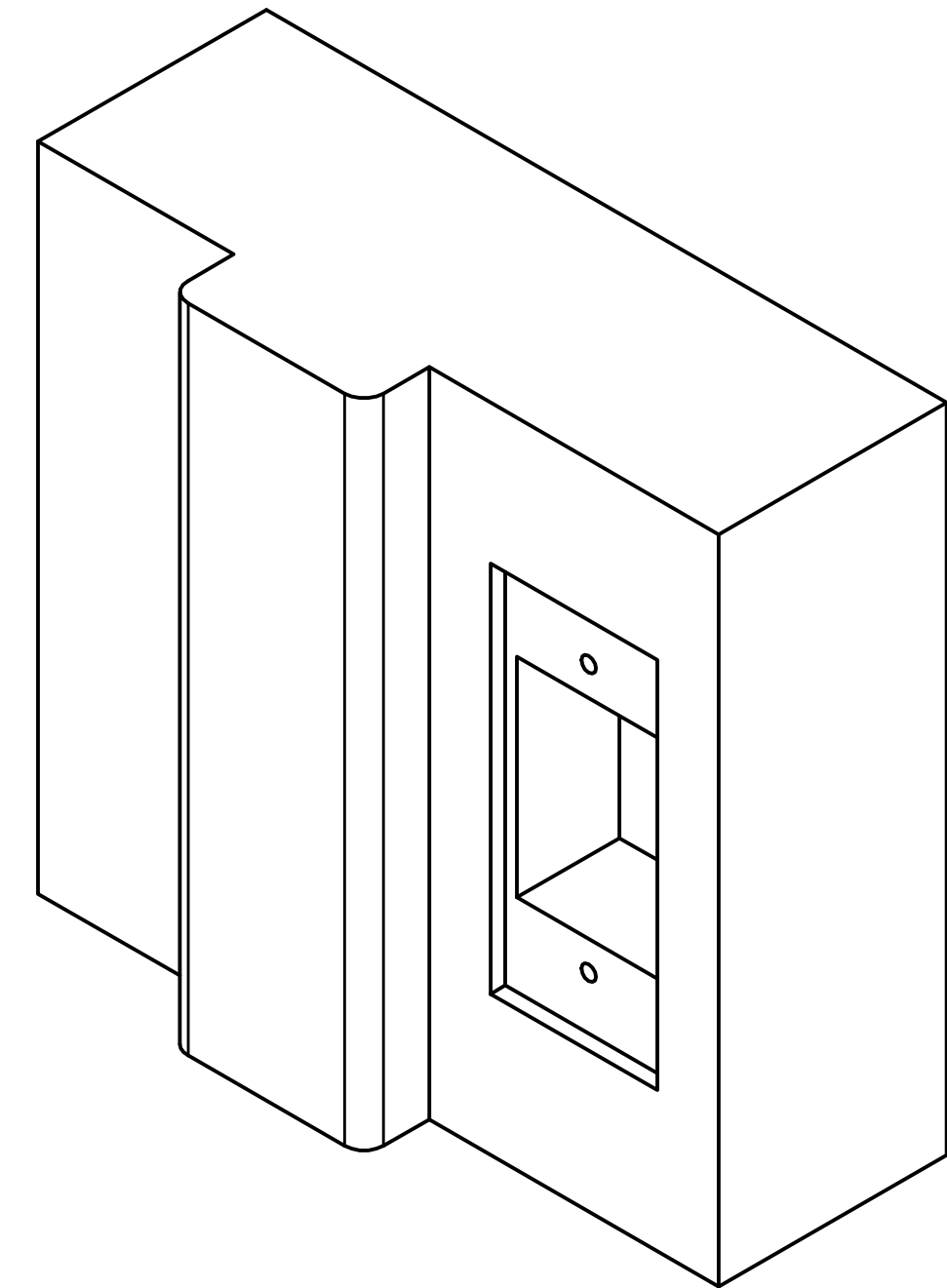

STRIKE CENTER LINE

TO BE DETERMINED BY
 GENERAL CONTRACTOR