

NOTES:

- 1) MATERIAL: WOOD SUBSTRATE.
- 2) ALL SQUARE RECESSED CAVITIES TO HAVE SQUARE CORNERS.
- 3) IF FOR A SINGLE SIDE FUNCTION, ONLY MACHINE TRIM CAVITY FOR THAT SPECIFIC HANDED DOOR PANEL.

Description:
**EP6 x RC-2 DOOR PREP
 FOR 1-3/8" AND 1-3/4" DOOR**



TOLERANCES UNLESS OTHERWISE SPECIFIED:
 X.X (METRIC)= ±0.5
 X.XX(METRIC)= ±0.15
 0.00"(UNIFIED)= ±.015"
 0.000"(UNIFIED)= ±.005"

Drawing No:
DP-417

Drawn By: **JWB**

Orig.Date: **06-11-24**

Rev. Date:

Rev.:

D

D

C

C

B

B

A

A

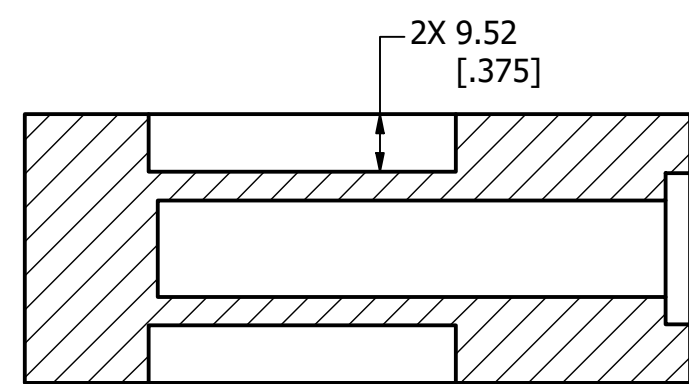
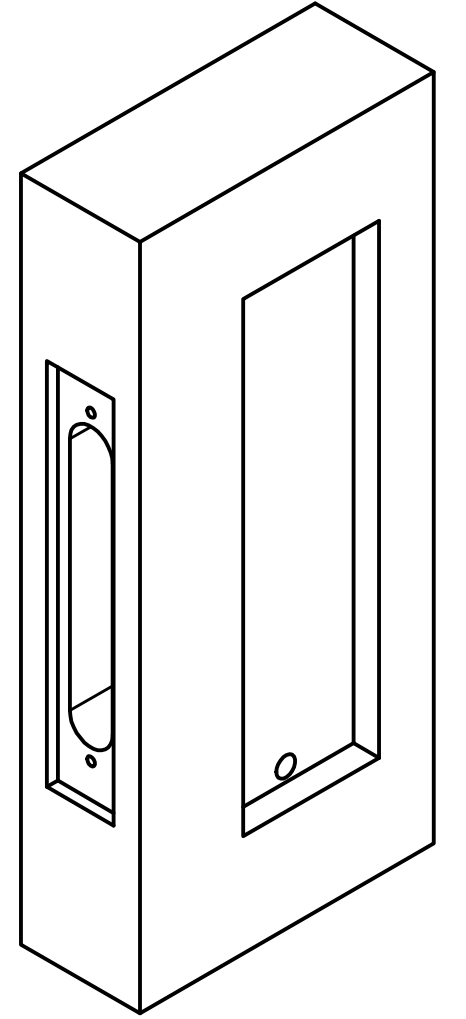
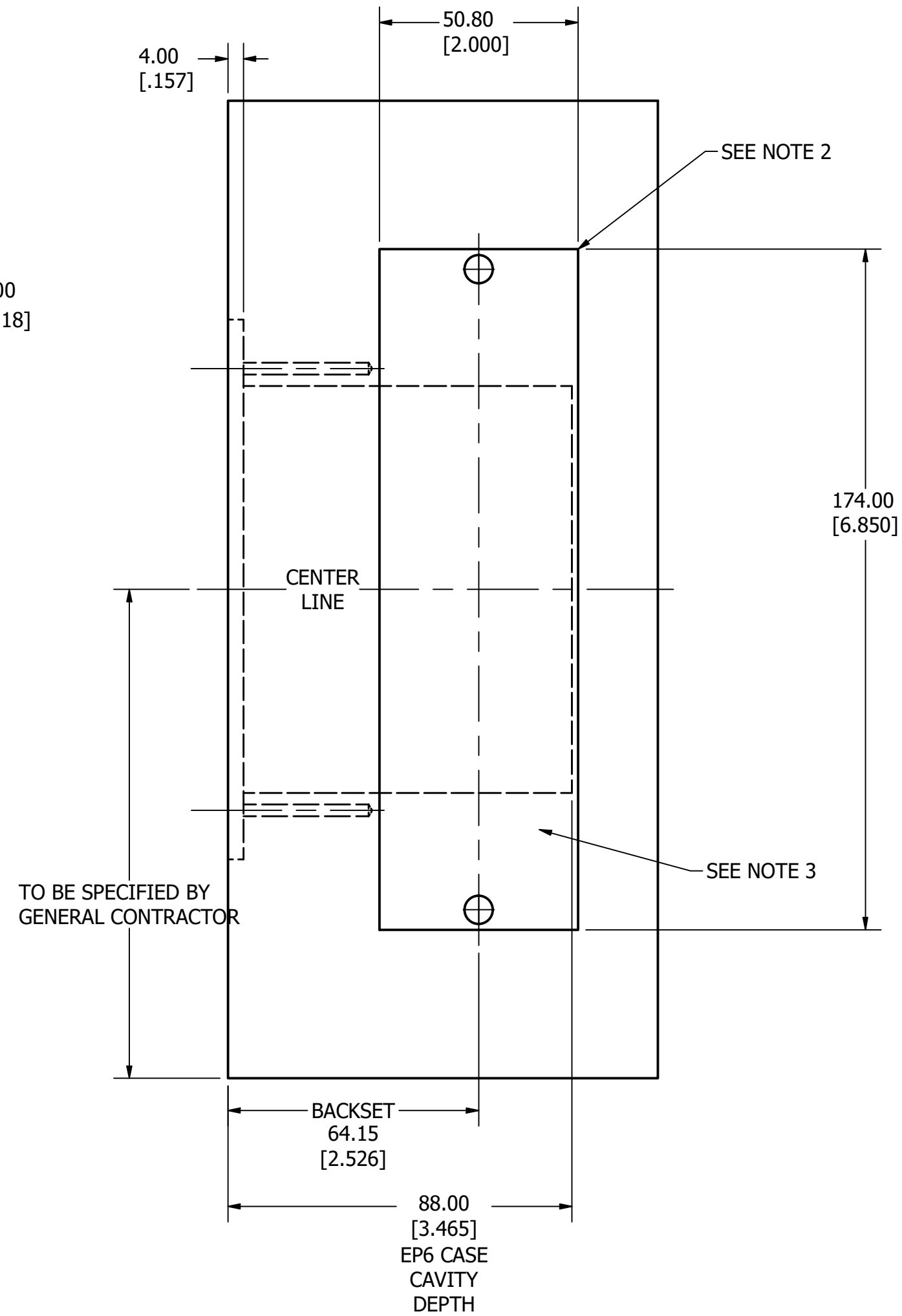
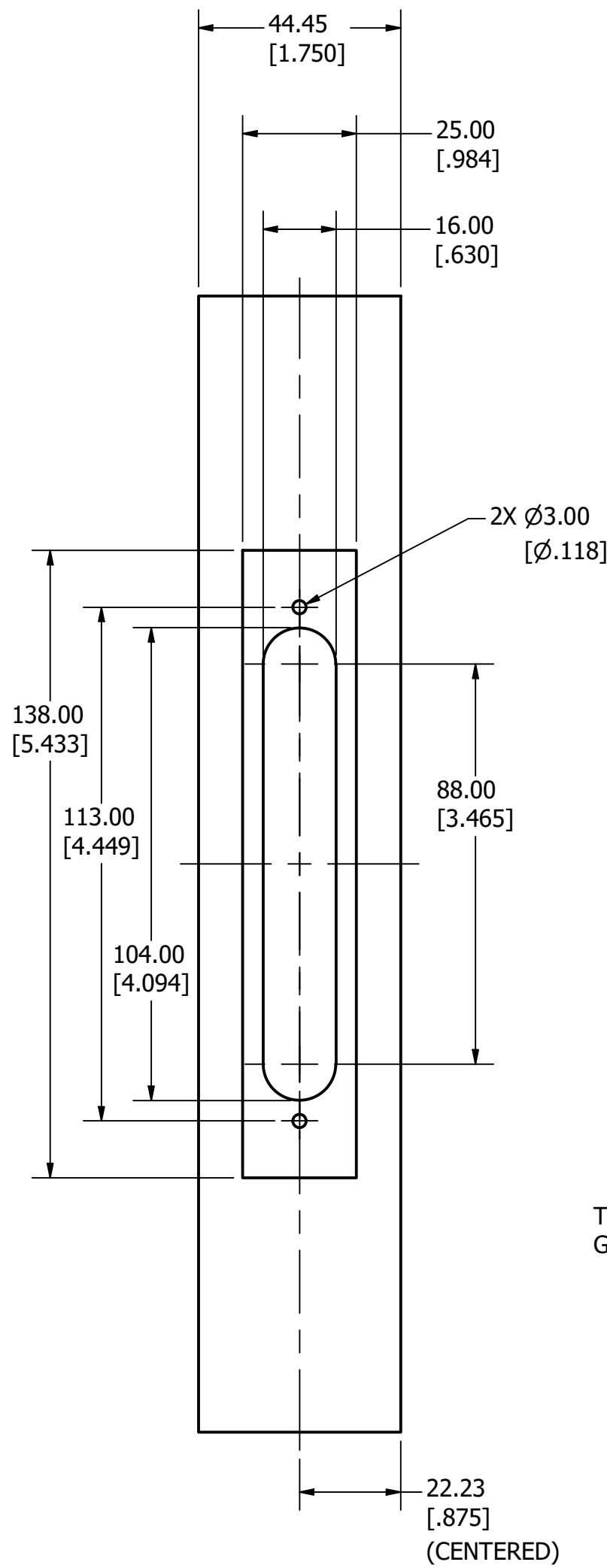
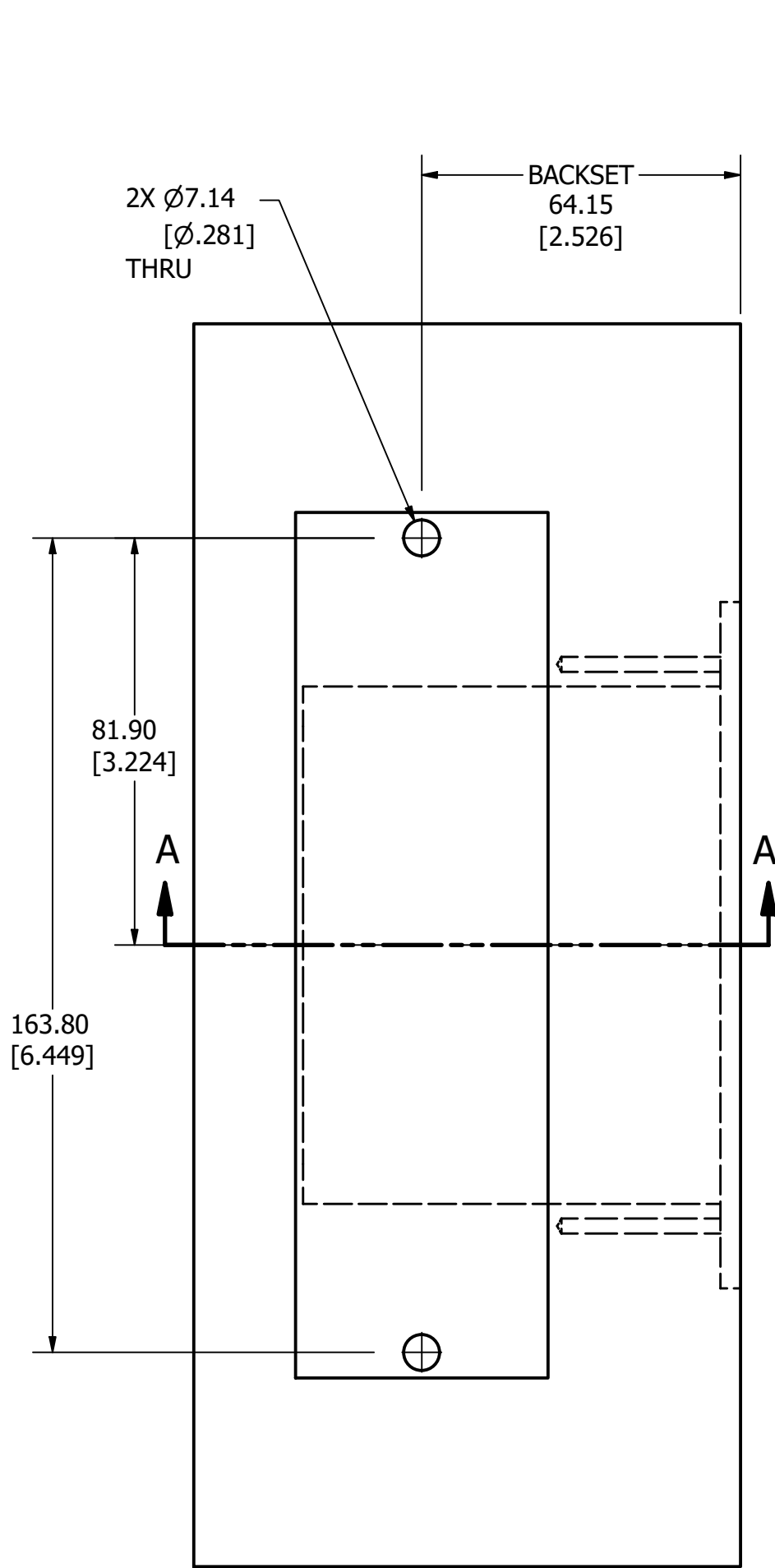

SECTION A-A

6

5

4

3

2

1

1