

- NOTES:
 1) NOT TO SCALE. DO NOT USE AS A DOOR TEMPLATE.
 2) REFER TO DP-156 FOR STRIKE PREPARATION GUIDE.
 3) SLIGHT MODIFICATION MAY BE NECESSARY FOR PROPER FIT.
 4) SHOWN, RIGHT HAND DOOR PREP.
 5) REFER TO SARGENT WEBSITE TEMPLATES FOR FURTHER INFORMATION ABOUT FUNCTIONS.

NOT TO SCALE

Description:
 SARGENT DOOR PREP.
 SERIES 8200 & 9200



TOLERANCES UNLESS OTHERWISE SPECIFIED:
 X.X (METRIC)= ±0.5
 X.XX (METRIC)= ±0.15
 0.00 (UNIFIED)= ±.015"
 0.000 (UNIFIED)= ±.005"

Drawing No:
 DP-258

Drawn By:
 JWJ

Orig.Date
 05-25-16

Rev. Date:
 03-03-20

Rev.:
 A

NOT TO SCALE



Ø17.46
 [Ø.687]
 TURN KNOB HOLE
 ONLY USE FOR
 LOCKSETS REQUIRING
 A TURN KNOB
 (SEE NOTE 5)



Ø31.75 CYLINDER HOLE
 [Ø1.250]
 ONLY USE FOR
 LOCKSETS REQUIRING
 A CYLINDER
 (SEE NOTE 5)

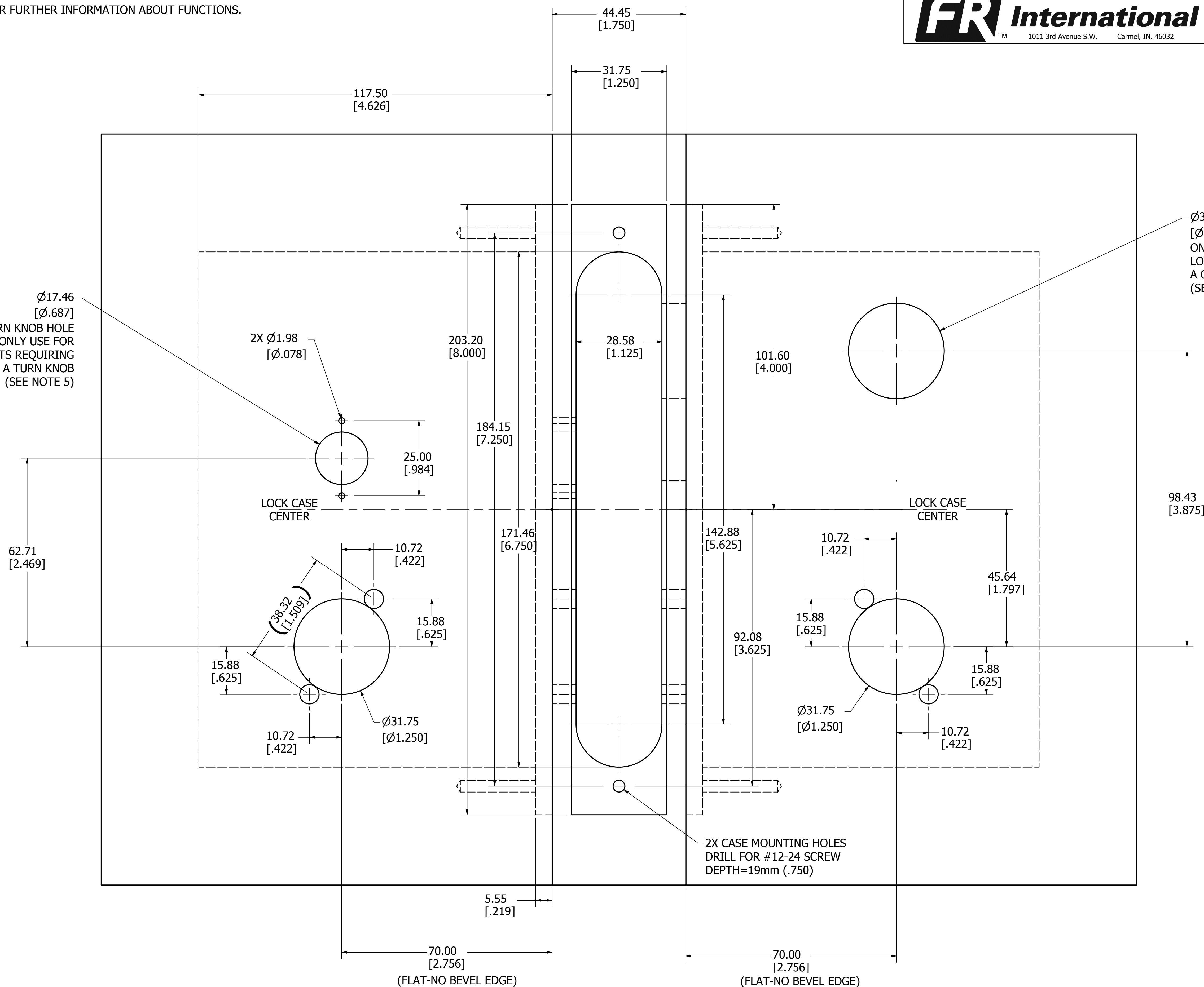

NOT TO SCALE

2X CASE MOUNTING HOLES
 DRILL FOR #12-24 SCREW
 DEPTH=19mm (.750)

70.00 [2.756]
 (FLAT-NO BEVEL EDGE)

70.00 [2.756]
 (FLAT-NO BEVEL EDGE)