

- NOTES:
- 1) DIMENSIONS "X" AND "Y" ARE VARIABLE DEPENDING ON DOOR THICKNESS.
 - 2) STRIKE LOCATION ON FRAMES MUST BE ADJUSTED FOR THICKNESS OF DOOR SILENCERS WHEN USED.
 - 3) FOR RIGHT HAND OPERATION, MIRROR DIMENSIONS TO OTHER SIDE OF JAMB.
 - 4) THIS DOOR PREP DRAWING IS NOT FULL SCALE--DO NOT USE AS FULL SIZE TEMPLATE.
 - 5) DO NOT DRILL THROUGH DOOR--ONE SIDE ONLY.
 - 6) FACEPLATE DEPTH IS 6mm WHEN USING FACEPLATE, SUPPORT PLATE AND STRIKE BOX. DRILL HOLES TO 76mm DEEP (3.00") FOR SUPPORT PLATE ONLY.

NOT FULL SCALE

Description:
B80 TKxBLIND HOLE TUBULAR DEADBOLT
DOOR PREP, 1-1/8" FACEPLATE

TOLERANCES UNLESS OTHERWISE SPECIFIED:
X.X (METRIC)= ±0.5
X.XX (METRIC)= ±0.15
0.00" (UNIFIED)= ±.015"
0.000" (UNIFIED)= ±.005"

Drawing No:
DP-133

Drawn By: **JWB**

Orig. Date: **02-27-13**

Rev. Date: **01-25-23** Rev.: **A**



1-1/8" STRIKE PREPARATION
(LEFT HAND SHOWN--SEE NOTE 5 FOR HANDING)

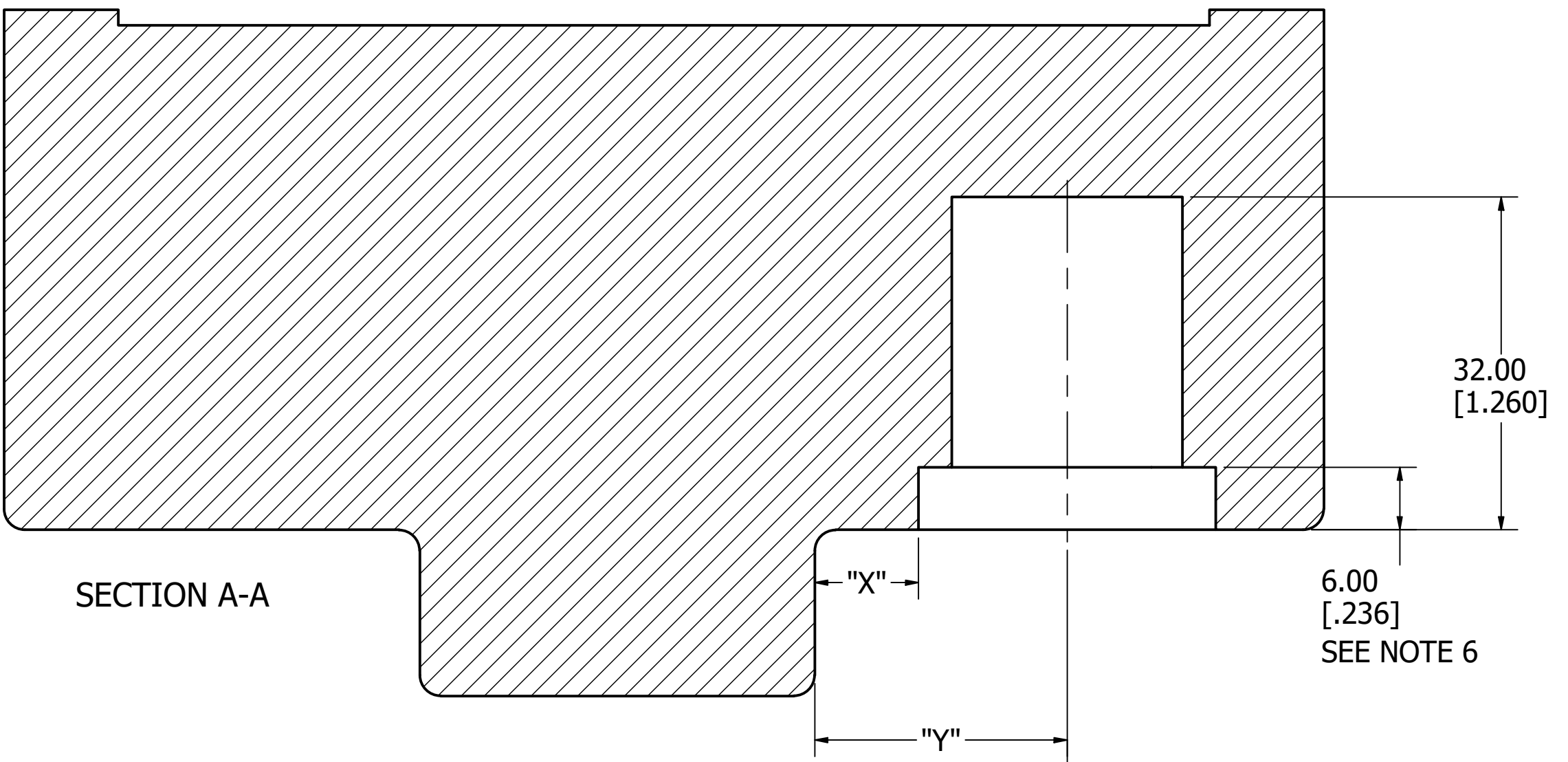

LATCH PREPARATION

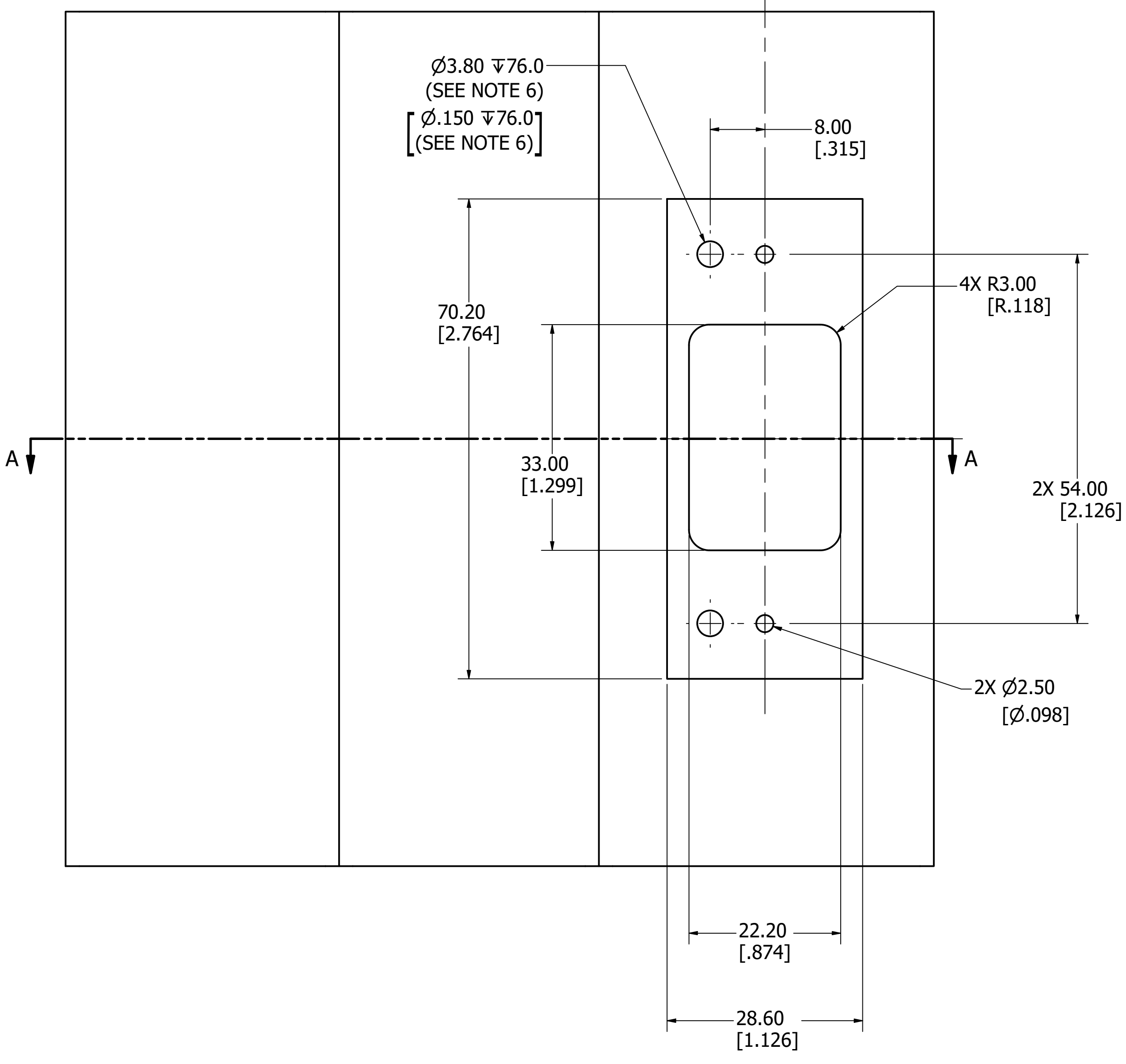
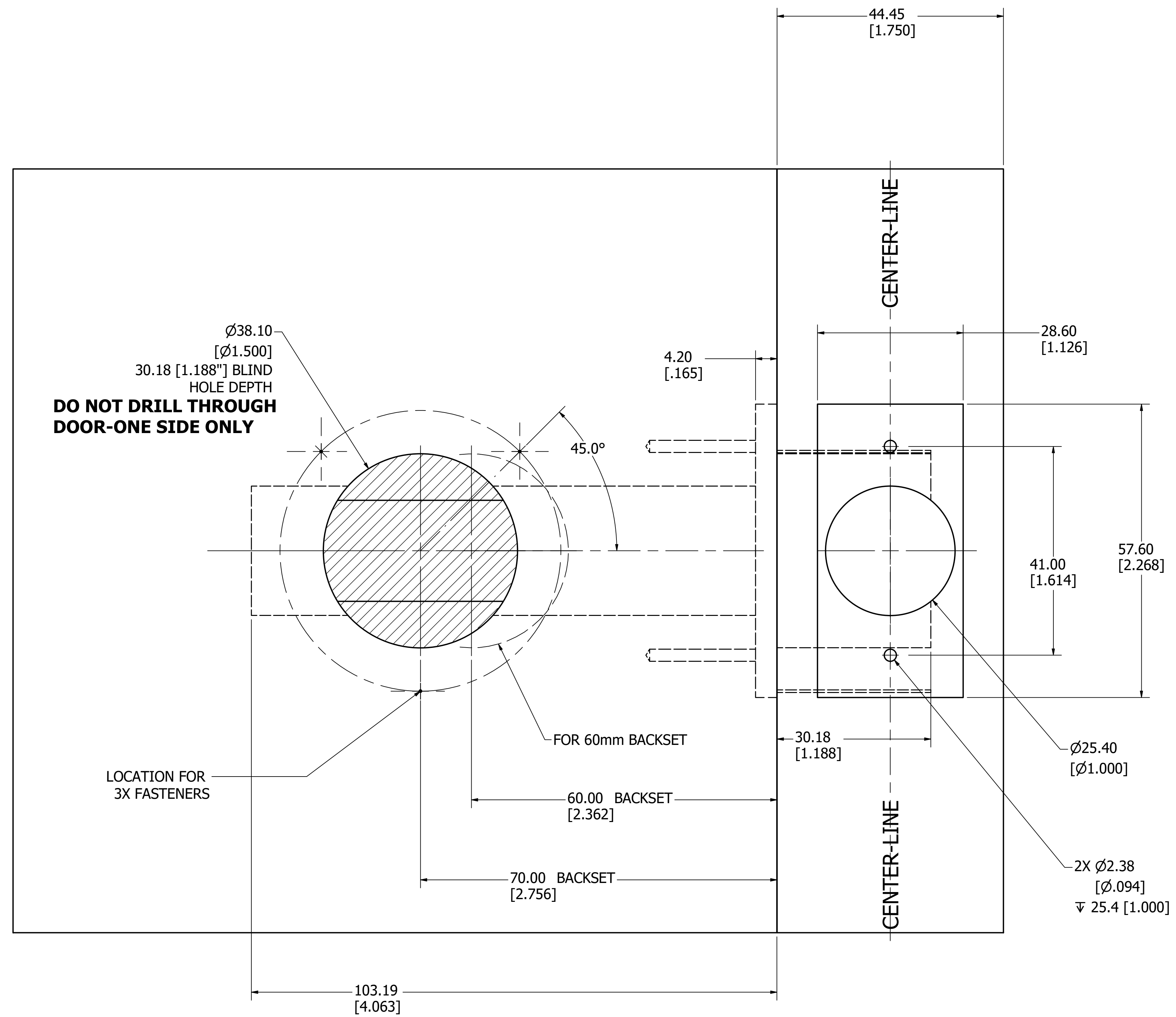

NOT FULL SCALE