

- NOTES:
- 1) MATERIAL: STAINLESS STEEL, 35mm GRIP.
 - 2) FINISH: AS SPECIFIED ON PURCHASE ORDER.
 - 3) WITH PLASTIC PROTECTIVE WASHERS.
 - 4) SUBSTRATE: 1/2" GLASS.
 - 5) IMAGE/VIEWS "NOT TO SCALE".
 - 6) LOCKING MECHANISM: INTERCHANGEABLE CORE AS SPECIFIED ON PURCHASE ORDER.
 - 7) WITH DUST PROOF STRIKE--FINISH TO MATCH PURCHASE ORDER.
 - 8) APPLY 3 STRIPS OF ADHESIVE TO OUTSIDE OF STRIKE WALLS PRIOR TO INSERTION--LET STAND OVERNIGHT TO CURE. TAKE CAUTION NOT TO GET ANY ADHESIVE ON FINISH AS THIS MAY REMOVE FINISH.

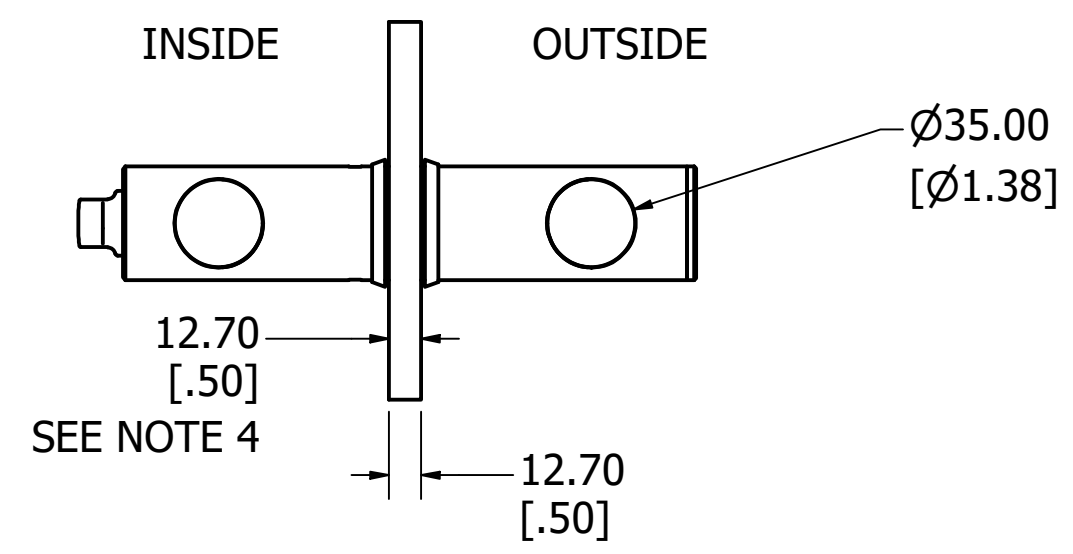

NOT TO SCALE

Description:
LDP1A1 813/1219 PULL ASSY
I.C. X TURN KNOB, .50" GLASS



TOLERANCES UNLESS OTHERWISE SPECIFIED:
X.X (METRIC) = ±0.5
X.XX (METRIC) = ±0.15
0.00" (UNIFIED) = ±.015"
0.000" (UNIFIED) = ±.005"

Drawing No:
A-5890

Drawn By: **JWB**

Orig. Date: **02-15-24**

Rev. Date: Rev.:

TABLE	
Date	Approval Signature

NOT TO SCALE

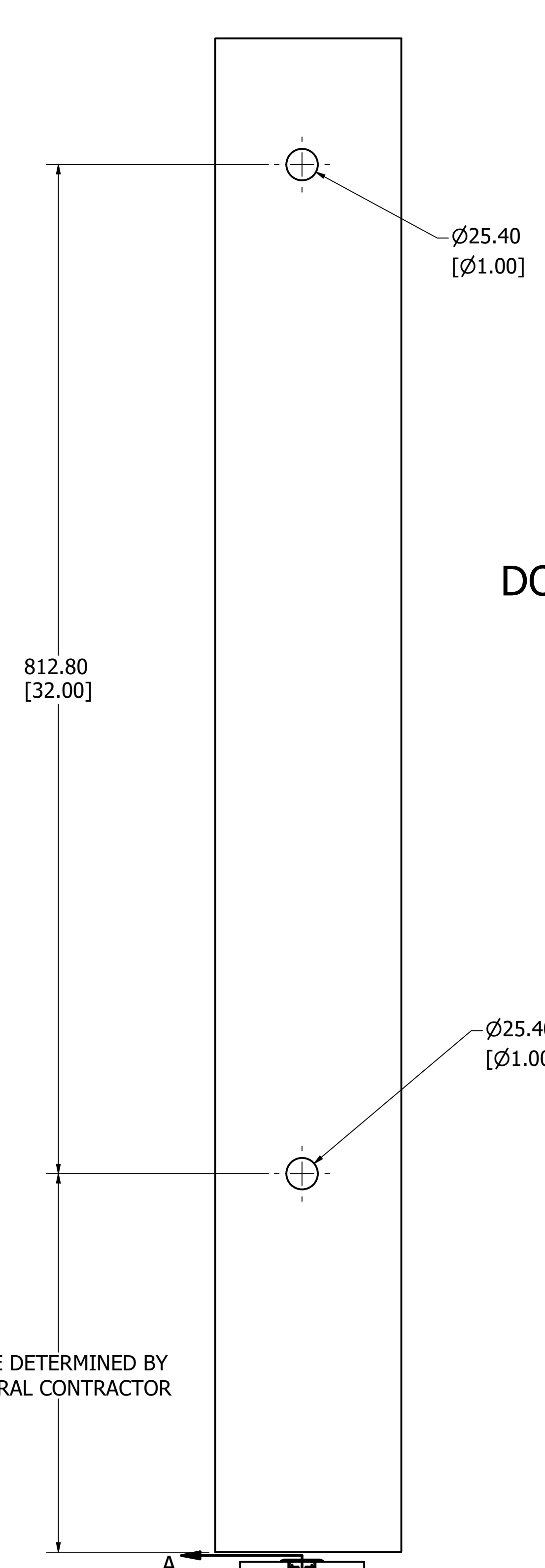
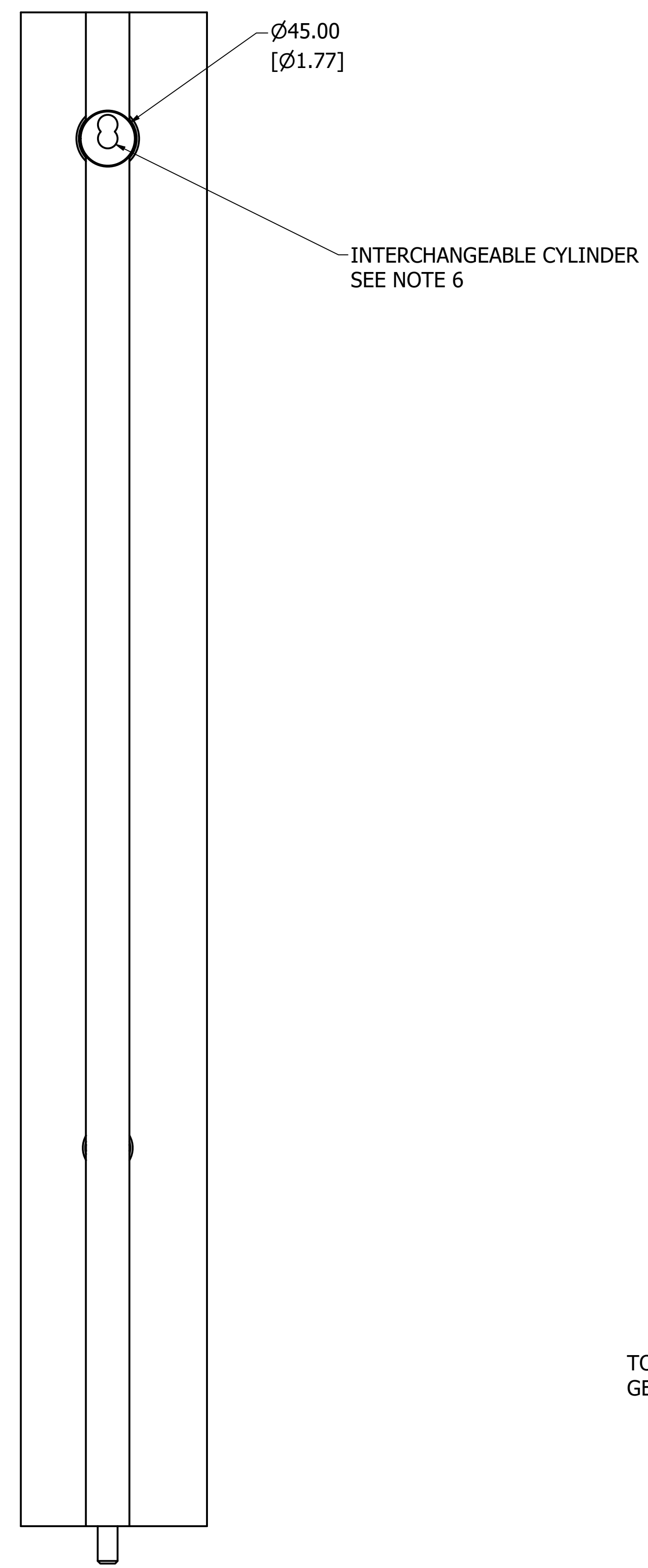
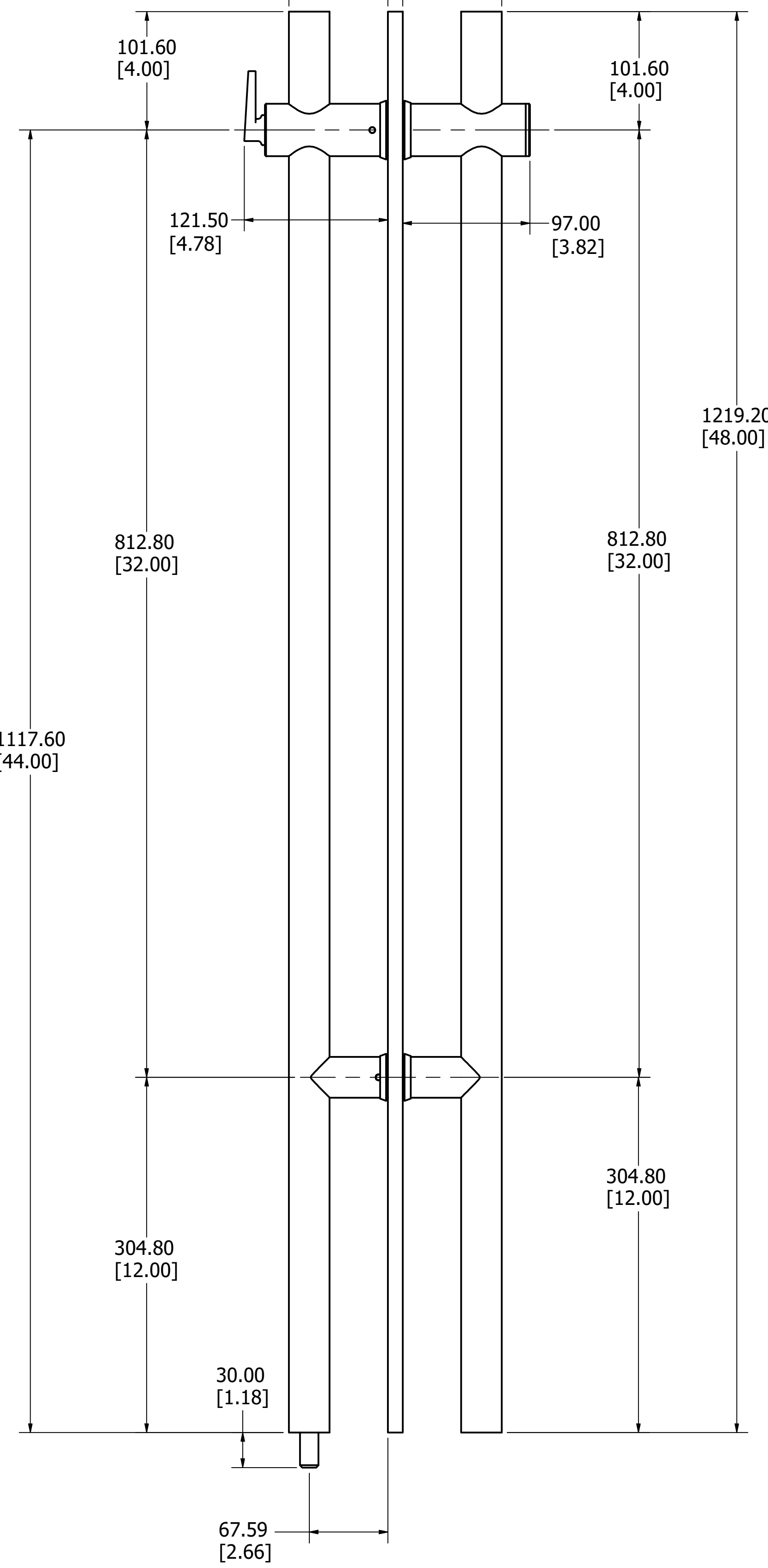
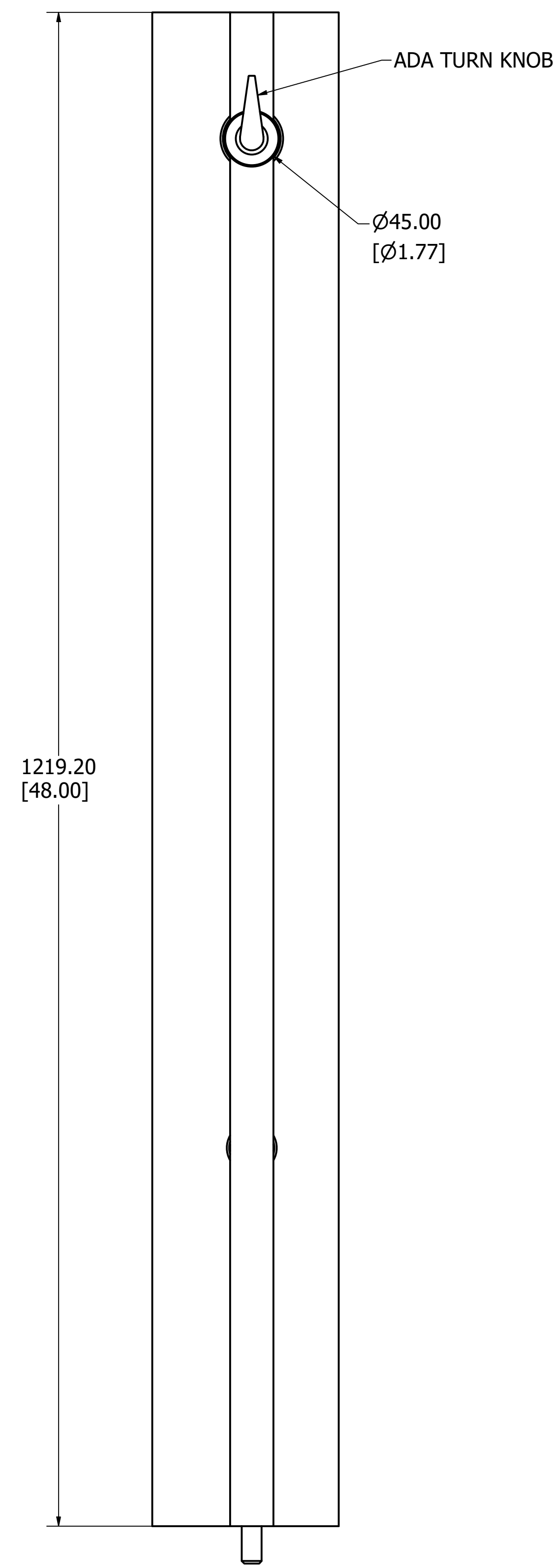

DOOR PREP.

DUST PROOF FLOOR STRIKE PREP.

TO BE DETERMINED BY GENERAL CONTRACTOR

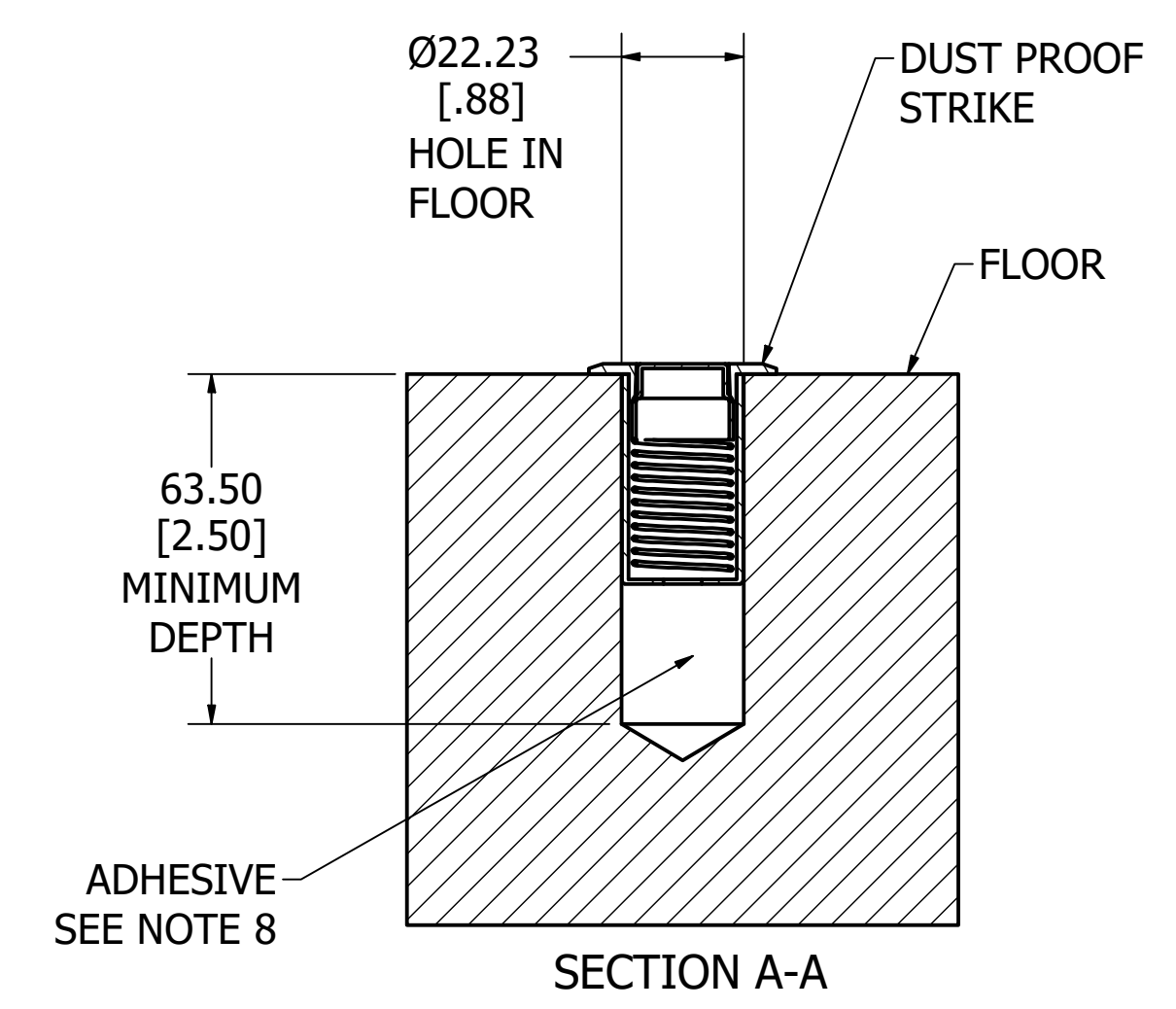

NOT TO SCALE